

# Panel Mount USB 2.0 cable A female screws to 5 pin board connector 20cm

Product number CU-MA5-020

Length 200mm



## Product description

Panel Mount USB 2.0 cable, 20cm, connector USB A female (mountable with 2 screws) to motherboard connector (5 pin, grid 2.54mm), screws included, for USB 2.0 and 1.1, max. 480 Mbps

## Highlights

- UL cable material, ideal for exports
- screws included
- alternative lengths available

## Technical data

- USB 2.0 panel mounting cable
- Connection 1: USB 2.0 A socket can be screwed on (recessed nuts on the side)
- Connection 2: 5-pin board connector for post field (grid dimension 2.54mm)
- Scope of delivery: Panel cable incl. 2 screws (pre-assembled)
- Screw type: UNC 4-40
- Screw spacing: 30mm (see drawing)
- **PREMIUM quality**
- **UL 2725** cable material from brand manufacturer e.g. E238846 CHINGLUNG
- Gold-plated contacts
- Cable material with **double shielding** (foil shield + braided shield)
- Data strands: 28 AWG/1P (twisted pair), copper (CU)
- Power strands: 5V thicker with 24 AWG/2C, copper (CU)
- USB 2.0 compatible + backwards compatible with USB 1.1
- suitable for 480 MBit/s (high speed), 12 MBit/s (full speed) and 1.5 MBit/s (low speed)
- Colour: grey-beige
- Brand: HORXX industrial
- Customs tariff no.: 85444290
- Alternative product designations: Enclosure feed-through, cable with panel jack, rack mount, panel mount, USB REAR

## Environmental protection

- CE, WEEE, RoHS compliant

More images

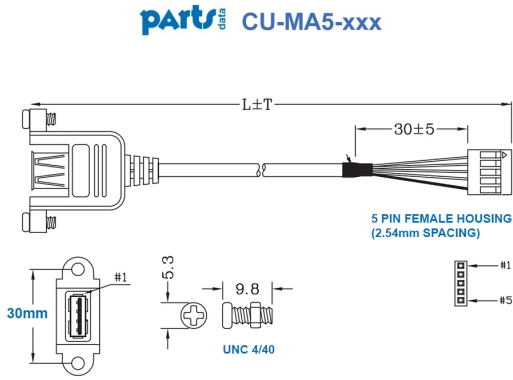

inkl. Schrauben  
screws included  
vis includes

partu data CU-MA5-xxx

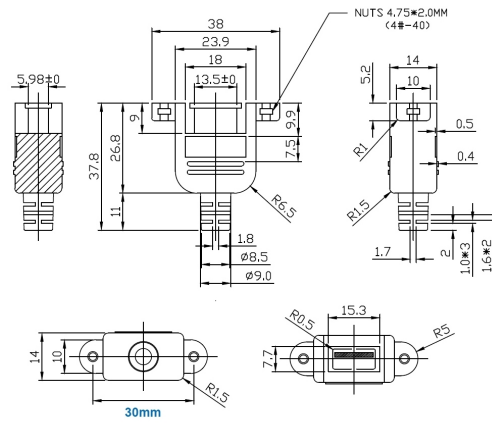

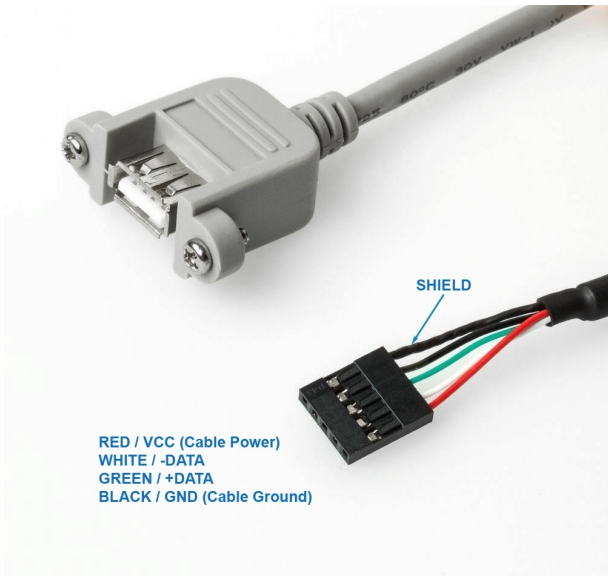

**part**<sub>data</sub> CU-MA5-xxx

